

ENGINE SERVICE MANUAL

MaxxForce® 11 and 13

Navistar, Inc.

2701 Navistar Drive, Lisle, IL 60532 USA

Summary of Changes

Section Updated	Description
Inlet Air Heater System	<ul style="list-style-type: none"> Installation procedure updated to reflect correct installation of the IAHF in the air intake throttle duct.
Aftertreatment System	<ul style="list-style-type: none"> Pre-Diesel Oxidation Catalyst (PDOC) – PDOC bracket and clamp updated with new parts. Hydrocarbon Injector (HCI) / Aftertreatment Fuel Injector (AFI) Assembly – Added information regarding correct orientation of AFI gasket (raised seal lip facing down toward exhaust back pressure valve housing). Special Torque- PDOC clamp torque updated.
Turbochargers	<ul style="list-style-type: none"> Improved installation procedure and graphics in Turbocharger Mounting .
Fuel System	<ul style="list-style-type: none"> Fuel Supply and Drain (Return) Lines – Updated removal and installation procedures to reflect relocation of c-clips. C-clips were relocated due to a rub condition that existed between the fuel filter supply line and the low pressure pump supply line. High-Pressure Fuel Pump (HPFP) and Drive Housing – HPFP removal and installation procedures updated to reflect removal of HPFP drive pulley and pulley housing off-vehicle. Fuel Pressure Control Valve (FPCV) and Piston Overflow Valve (KUEV) – Procedures added for removal and installation of the FPCV and KEUV.
Cylinder Head, Camshaft and Valve Train	<ul style="list-style-type: none"> Valve Lash Adjustment Procedure – A note has been added identifying the proper service interval for valve lash adjustment. Upper Valve Cover and Base – Tightening sequence added for 18 valve cover base screws with dampers.
Power Cylinders	<ul style="list-style-type: none"> Piston and Connecting Rod Installation – Steps for checking proper connecting rod to rod cap orientation. Also a caution and step has been added regarding cleaning fractured mating surfaces of the connecting rod and rod cap.

TABLE OF CONTENTS

Foreword.....	1
Service Diagnosis.....	2
Safety Information.....	3
Engine Systems.....	5
Mounting Engine on Stand.....	57
Engine Electrical.....	65
Inlet Air Heater System.....	113
Aftertreatment System.....	125
Exhaust Back Pressure Control.....	149
Turbochargers.....	163
Air Compressor and Power Steering.....	213
Fuel System.....	227
Oil Cooler, Filter Housing, and Crankcase Ventilation.....	281
Exhaust Gas Recirculation (EGR) System.....	299
Air Intake Throttle Duct and Exhaust Manifold.....	335
Front Cover, Fan Drive, Cooling System, and Related Components.....	357
MaxxFace® Engine Brake by Jacobs.....	387
Cylinder Head, Camshaft and Valve Train.....	403
Flywheel and Flywheel Housing.....	439
Oil Pan and Oil Pickup Tube.....	457
Oil Pump and Timing Gears.....	473
Power Cylinders.....	489
Crankcase and Crankshaft.....	509
Abbreviations and Acronyms.....	523
Terminology.....	529

Appendix A – Specifications.....541

Appendix B – Torques.....547

Appendix C – Special Service Tools.....565

Appendix D – Technical Service Information (TSI).....581

Foreword

Navistar, Inc. is committed to continuous research and development to improve products and introduce technological advances. Procedures, specifications, and parts defined in published technical service literature may be altered.

This *Engine Service Manual* provides a general sequence of procedures for out-of-chassis engine overhaul (removal, inspection, and installation). For in-chassis service of parts and assemblies, the sequence may vary.

NOTE: Photo illustrations identify specific parts or assemblies that support text and procedures; other areas in a photo illustration may not be exact.

See vehicle manuals and Technical Service Information (TSI) bulletins for additional information.

MaxxForce® 11 and 13 and N13 with SCR *Engine Operation and Maintenance Manual*

MaxxForce® 11 and 13 *Engine Service Manual* (EPA 10)

MaxxForce® 11 and 13 *Engine Diagnostic Manual* (EPA 10)

MaxxForce® 11 and 13 *Hard Start and No Start Diagnostics Form* (EPA 10)

MaxxForce® 11 and 13 *Performance Diagnostics Form* (EPA 10)

MaxxForce® 11 and 13 *Electronic Control System Diagnostics Form* (EPA 10)

Technical Service Literature is revised periodically. If a technical publication is ordered, the latest revision will be supplied.

NOTE: To order technical service literature, contact your International dealer.

All marks are trademarks of their respective owners.

Service Diagnosis

Service diagnosis is an investigative procedure that must be followed to find and correct an engine application problem or an engine problem.

If the problem is engine application, see specific vehicle manuals for further diagnostic information.

If the problem is the engine, see specific *Engine Diagnostic Manual* for further diagnostic information.

Prerequisites for Effective Diagnosis

- Availability of gauges, diagnostic test equipment, and diagnostic software.
- Availability of current information for engine application and engine systems.

- Knowledge of the principles of operation for engine application and engine systems.
- Knowledge to understand and do procedures in diagnostic and service publications.

Technical Service Literature required for Effective Diagnosis

- *Engine Service Manual*
 - *Engine Diagnostic Manual*
 - Diagnostics Forms
 - Electronic Control Systems Diagnostics Forms
 - Service Bulletins
-

Safety Information

This manual provides general and specific maintenance procedures essential for reliable engine operation and your safety. Since many variations in procedures, tools, and service parts are involved, advice for all possible safety conditions and hazards cannot be stated.

Read safety instructions before doing any service and test procedures for the engine or vehicle. See related application manuals for more information.

Obey Safety Instructions, Warnings, Cautions, and Notes in this manual. Not following warnings, cautions, and notes can lead to injury, death or damage to the engine or vehicle.

Safety Terminology

Three terms are used to stress your safety and safe operation of the engine: Warning, Caution, and Note

Warning: A warning describes actions necessary to prevent or eliminate conditions, hazards, and unsafe practices that can cause personal injury or death.

Caution: A caution describes actions necessary to prevent or eliminate conditions that can cause damage to the engine or vehicle.

Note: A note describes actions necessary for correct, efficient engine operation.

Safety Instructions

Work Area

- Keep work area clean, dry, and organized.
- Keep tools and parts off the floor.
- Make sure the work area is ventilated and well lit.
- Make sure a First Aid Kit is available.

Safety Equipment

- Use correct lifting devices.
- Use safety blocks and stands.

Protective Measures

- Wear protective safety glasses and shoes.
- Wear correct hearing protection.
- Wear cotton work clothing.
- Wear sleeved heat protective gloves.

- Do not wear rings, watches or other jewelry.
- Restrain long hair.

Vehicle

- Shift transmission to park or neutral, set parking brake, and block wheels before doing diagnostic or service procedures.
- Clear the area before starting the engine.

Engine

- The engine should be operated or serviced only by qualified individuals.
- Provide necessary ventilation when operating engine in a closed area.
- Keep combustible material away from engine exhaust system and exhaust manifolds.
- Install all shields, guards, and access covers before operating engine.
- Do not run engine with unprotected air inlets or exhaust openings. If unavoidable for service reasons, put protective screens over all openings before servicing engine.
- Shut engine off and relieve all pressure in the system before removing panels, housing covers, and caps.
- If an engine is not safe to operate, tag the engine and ignition key.

Fire Prevention

- Make sure charged fire extinguishers are in the work area.

NOTE: Check the classification of each fire extinguisher to ensure that the following fire types can be extinguished.

1. Type A — Wood, paper, textiles, and rubbish
2. Type B — Flammable liquids
3. Type C — Electrical equipment

Batteries

- Always disconnect the main negative battery cable first.
- Always connect the main negative battery cable last.
- Avoid leaning over batteries.

- Protect your eyes.
- Do not expose batteries to flames or sparks.
- Do not smoke in workplace.

Compressed Air

- Use an OSHA approved blow gun rated at 207 kPa (30 psi).
- Limit air pressure to 207 kPa (30 psi).
- Wear safety glasses or goggles.
- Wear hearing protection.
- Use shielding to protect others in the work area.
- Do not direct compressed air at body or clothing.

Tools

- Make sure all tools are in good condition.
- Make sure all standard electrical tools are grounded.

- Check for frayed or damaged power cords before using power tools.

Fluids Under Pressure

- Use extreme caution when working on systems under pressure.
- Follow approved procedures only.

Fuel

- Do not over fill the fuel tank. Over fill creates a fire hazard.
- Do not smoke in the work area.
- Do not refuel the tank when the engine is running.

Removal of Tools, Parts, and Equipment

- Reinstall all safety guards, shields, and covers after servicing the engine.
 - Make sure all tools, parts, and service equipment are removed from the engine and vehicle after all work is done.
-

Table of Contents

Engine Identification.....	7
Engine Serial Number.....	7
Engine Emission Label	7
Engine Accessory Labels and Identification Plates.....	8
Engine Specifications.....	8
Heavy Duty On Board Diagnostics (HD-OBD).....	10
Engine Description.....	10
Optional Equipment.....	11
Chassis Mounted Equipment.....	11
Engine Component Locations.....	12
Air Management System.....	16
Airflow.....	17
Turbochargers.....	18
Air Control Valve (ACV).....	19
Boost Control.....	19
Low-Pressure Charge Air Cooler (LPCAC).....	19
High-Pressure Charge Air Cooler (HPCAC).....	19
High-Pressure Boost Pressure (HPBP) Sensor	20
High-Pressure Boost Temperature (HPBT) Sensor	20
Low-Pressure Boost Pressure (LPBP) Sensor and Low-Pressure Boost Temperature (LPBT) Sensor	20
Exhaust Gas Recirculation (EGR) System.....	21
Aftertreatment (AFT) System.....	24
Diesel Particulate Filter (DPF).....	25
Diesel Oxidation Catalyst (DOC).....	25
Aftertreatment (AFT) System Conditions and Responses.....	25
Downstream Fuel Injection.....	26
Crankcase Oil Separator.....	28
Fuel Management System.....	30
Fuel System.....	30
Fuel Flow.....	31
Low-Pressure Fuel System.....	32
High-Pressure Fuel System.....	34
Inlet Air Heater System.....	35
Inlet Air Heater System Components.....	35
Inlet Air Heater System Operation.....	36
Oil Flow and Components.....	37
Engine Cooling System.....	41
Cooling System Flow.....	41
Thermostat Operation.....	42
Coolant Control Valve (CCV) operation.....	43

Engine Brake System	44
Engine Brake Control System Components	44
Engine Brake System Operation	46
Electronic Control System	47
Electronic Control System Components	47
Operation and Function	47
Reference Voltage (VREF)	47
Signal Conditioner	47
Microprocessor	47
Diagnostic Trouble Codes	47
Microprocessor Memory	47
Actuator Control	48
Actuators	48
Coolant Control Valve (CCV)	48
Exhaust Back Pressure Valve (EBPV) Control	48
Exhaust Gas Recirculation (EGR) Valve	48
Air Control Valve (ACV)	48
Inlet Air Heater Relay (IAHR)	48
Inlet Air Heater Fuel Solenoid (IAHFS) Valve	49
Engine Throttle Valve (ETV)	49
Fuel Pressure Control Valve (FPCV)	49
Aftertreatment Fuel Doser (AFTFD)	49
Aftertreatment Shutoff Valve (AFTSV)	49
Engine and Vehicle Sensors	49
Thermistor Sensors	49
Variable Capacitance Sensors	51
Magnetic Pickup Sensors	52
Potentiometer Sensors	53
Switches	54
Additional Sensors	55
Oxygen Sensor (O2S)	55
Humidity Sensor (HS)	55

Engine Identification

Engine Serial Number

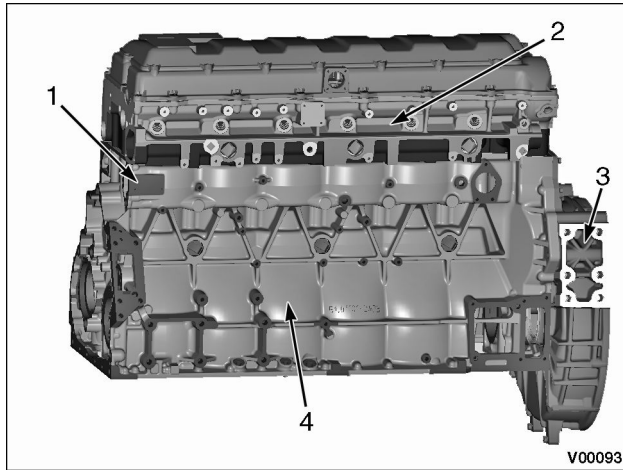

Figure 1 Engine serial number

1. Engine Serial Number (ESN) location
2. Cylinder head
3. Flywheel housing
4. Crankcase

The Engine Serial Number (ESN) is located on the front of the crankcase (left side), below the cylinder head.

Engine Serial Number Examples

MaxxForce® 11: 106HM2XXXXXXXX

MaxxForce® 13: 125HM2XXXXXXXX

MaxxForce® 11: 106HM2YXXXXXXXX

MaxxForce® 13: 125HM2YXXXXXXXX

Engine Serial Number Codes

106 – Engine displacement (10.5 L)

125 – Engine displacement (12.4 L)

H – Diesel, turbocharged, Charge Air Cooler (CAC), and electronically controlled

M2 – Motor truck

Y – Huntsville, Alabama

7 digit suffix – Engine serial number sequence

Engine Emission Label

IMPORTANT ENGINE INFORMATION ENGINE MANUFACTURED BY: NAVISTAR, INC.	
MODEL YEAR	2012
ADV BHP @ RPM	390@1700
	*
LB-FT TORQ. @ RPM	1450@1000
	*
DISPLACEMENT	10.5L
ENGINE S/N	1S1106HM2Y0000001
MODEL	A390
ENGINE FAMILY	MAXXFORCE 11
EMISSIONS FAMILY	BNVXH08410GA
LABEL NUMBER	3014508C1
VALVE LASH-COLD: 0.500mm (.020in) INT 0.800mm (.031in) EXH	
EMISSIONS CONTROL SYSTEMS DFI, TC(2), ECM, CAC(2), EGR, OC(2), PTOX	
FAMILY EMISSION LIMITS (g/bhp-hr) 0.50 MOx	
THIS ENGINE HAS A PRIMARY INTENDED SERVICE APPLICATION AS A HEAVY HEAVY-DUTY DIESEL ENGINE AND CONFORMS TO U.S. EPA, CALIFORNIA AND CANADIAN REGULATIONS APPLICABLE FOR 2012 MODEL YEAR AND IS CERTIFIED TO OPERATE ON ULTRA LOW SULFUR DIESEL FUEL. THIS ENGINE IS NOT CERTIFIED FOR THE USE IN AN URBAN BUS AS DEFINED AT 40CFR66.083-2. SALE OF THIS ENGINE FOR USE IN AN URBAN BUS IS A VIOLATION OF FEDERAL LAW UNDER THE CLEAN AIR ACT.	
THIS ENGINE IS CERTIFIED CLEAN IDLE IN ACCORDANCE WITH TITLE 13 CALIFORNIA CODE OF REGULATIONS SECTION 1956.8 (a) (6) (C)	
THIS ENGINE MEETS EMD REQUIREMENTS	

CURB IDLE, FUEL RATE @ ADV., POWER AND INJECTION TIMING ARE NON-ADJUSTABLE

V35406

Figure 2 2012 U.S. Environmental Protection Agency (EPA) exhaust emission label (example)

The U.S. Environmental Protection Agency (EPA) exhaust emission label is on top of the valve cover (front left side). The EPA label typically includes the following:

- Model year
- Engine family, model, and displacement
- Advertised brake horsepower and torque rating
- Emission family and control systems
- Valve lash specifications
- ESN
- EPA, Onboard Diagnostics (OBD), EURO, and reserved fields for specific applications

Engine Accessory Labels and Identification Plates

The following engine accessories may have manufacturer's labels or identification plates:

- Air compressor
- Air conditioning compressor
- Alternator
- Cooling fan clutch
- Engine Control Module (ECM)
- High-pressure (HP) fuel pump
- Power steering pump
- Starter motor
- Turbochargers

Engine Specifications

MaxxForce® 11 and 13 Diesel Engines

Engine Configuration	4 stroke, inline six cylinder diesel
Advertised brake horsepower @ rpm	
• MaxxForce® 11	See EPA exhaust emission label
• MaxxForce® 13	See EPA exhaust emission label
Peak torque @ rpm	
• MaxxForce® 11	See EPA exhaust emission label
• MaxxForce® 13	See EPA exhaust emission label
Displacement	
• MaxxForce® 11	10.5 L (641 in ³)
• MaxxForce® 13	12.4 L (758 in ³)
Compression ratio	
• MaxxForce® 11	16.5:1
• MaxxForce® 13	17.0:1
Stroke	
• MaxxForce® 11	155 mm (6.10 in)
• MaxxForce® 13	166 mm (6.54 in)
Bore (sleeve diameter)	
• MaxxForce® 11	120 mm (4.72 in)
• MaxxForce® 13	126 mm (4.96 in)

 Total engine weight (dry weight without trim or accessories)

- MaxxForce® 11 1087 kgs (2392 lbs)
- MaxxForce® 13 1087 kgs (2392 lbs)

Firing order 1-5-3-6-2-4

Engine rotation direction (facing flywheel) Counterclockwise

Aspiration Dual turbocharged and charge air cooled

Combustion system Direct injection turbocharged

Fuel system High-pressure common rail

Lube system capacity (including filter)

- MaxxForce® 11 40 L (42 qts)
- MaxxForce® 13 40 L (42 qts)

Lube system capacity (overhaul only, with filter)

- MaxxForce® 11 44 L (46 qts)
- MaxxForce® 13 44 L (46 qts)

Engine oil pressure at operating temperature with SAE 15W-40 oil

- Low idle 69 kPa (10 psi) min
- High idle 276-483 kPa (40-70 psi)

Idle speed (no load) 600 rpm, nominal

Thermostat operating temperature

- Primary 83 °C - 95 °C (181 °F - 203 °F)
 - Secondary 87 °C - 102 °C (189 °F - 216 °F)
-

Heavy Duty On Board Diagnostics (HD-OBD)

The EPA has added new regulations for 2010 to reduce heavy duty vehicle emissions. The HD-OBD system is designed specifically for electronically controlled heavy duty engines. The key goal for HD-OBD regulation is to keep engine emissions in specification for as long as a given vehicle is in use.

HD-OBD is legislated to be implemented in three phases:

- 2010: First engine for each Original Equipment Manufacture (OEM) becomes fully certified.
 - The lead engine is determined by a legislated equation based on projected sales volume and useful life of the engine.
 - For Navistar®, this is the EPA 2010 MaxxForce® 13 engine.
- 2013: One engine in each engine family becomes fully certified.
 - This will be the largest step of the three phases.
- 2016: All engines must be fully HD-OBD certified.

The HD-OBD system continuously monitors for proper engine operation, and will alert the vehicle operator to emission-related faults using the Malfunction Indicator Lamp (MIL).

The MIL is installed in the Electronic Instrument Cluster. When a detected emissions fault occurs, the MIL will be illuminated. Diagnostic information is also stored in the ECM, and may be accessed by the technician for diagnosis and repair of the malfunction. Diagnostic information is accessed by connecting the Electronic Service Tool (EST) to the in-cab Diagnostic Connector.

Engine Description

The MaxxForce® 11 and 13 diesel engines are designed for increased durability, reliability, and ease of maintenance.

The cylinder head has four valves per cylinder for increased airflow. The overhead valve train includes rocker arms and valve bridges to operate the four valves. The fuel injector is centrally located between the four valves, directing fuel over the piston for improved performance and reduced emissions.

The overhead camshaft is supported by seven bearings in the cylinder head. The camshaft gear is driven from the rear of the engine. The overhead valve train includes roller rocker arms and dual valves that open, using a valve bridge. For 2010, the camshaft has been redesigned to incorporate six additional lobes. These new lobes are used with the engine brake housings for operation of the MaxxForce® Engine Brake.

The MaxxForce® 11 engines use aluminum pistons, and the MaxxForce® 13 engines use one piece steel pistons. All pistons use an offset piston axis and centered combustion bowls. Crown markings show correct piston orientation in the crankcase.

The one-piece crankcase uses replaceable wet cylinder liners that are sealed by dual crevice seals.

The crankshaft has seven main bearings with fore and aft thrust controlled at the sixth bearing. One fractured cap connecting rod is attached at each crankshaft journal. The piston pin moves freely inside the connecting rod and piston. Piston pin retaining rings secure the piston pin in the piston. The rear oil seal carrier is part of the flywheel housing.

A gerotor lube oil pump is mounted behind the front cover and is driven by the crankshaft. Pressurized oil is supplied to various engine components. All MaxxForce® 11 and 13 engines also use an engine oil cooler and a cartridge-style engine oil filter, which are located in the engine lube oil module.

The low-pressure fuel pump draws fuel from the fuel tank(s) through a chassis mounted filter/water separator. The low-pressure fuel pump provides fuel for the engine mounted fuel module. Conditioned low-pressure fuel is supplied from the engine mounted fuel module to the high-pressure fuel pump, Inlet Air Heater Fuel Solenoid (IAHFS), and the Downstream Injection (DSI) unit.

The high-pressure fuel system is a direct fuel injected common-rail system. The common-rail includes a high-pressure fuel pump, two fuel rail supply lines, fuel rail, six fuel injectors, and pressure limiting valve.

The fuel injectors are installed in the cylinder head under the valve cover and are electronically actuated by the ECM.

MaxxForce® 11 and 13 engines use a dual stage, fixed geometry turbocharger assembly. The high-pressure (HP) turbocharger includes a

pneumatically operated wastegate. Each stage uses a Charge Air Cooler (CAC). The Low Pressure Charge Air Cooler (LPCAC) is mounted on the lower right side of the engine, and uses the engine cooling system to regulate charge air temperatures. The High Pressure Charge Air Cooler (HPCAC) is mounted in front of the engine cooling package. The HPCAC is an air-to-air type cooler, and requires no connections to the engine's cooling system.

The Exhaust Gas Recirculation (EGR) system circulates cooled exhaust into the stream in the air inlet duct. The dual stage EGR cooler provides regulated cooling of the EGR gases before entering the air intake duct. This cools the combustion process, and reduces Nitrogen Oxides (NO_x) emissions.

The open crankcase breather system uses a centrifugal Crankcase Oil Separator (CCOS) to return oil mist to the crankcase, and vent the cleaned crankcase gasses to the atmosphere. The CCOS is part of the oil module. The breather system has been redesigned, and uses no crankcase breather filter or external piping. Blowby gases enter the CCOS directly through the side of the crankcase.

The inlet air heater assist system warms the incoming air supply prior to and during cranking.

The MaxxF[®] Engine Brake by Jacobs[®] is optional for both MaxxF[®] 11 and 13 engine displacements. The engine brake is a compression release system that provides additional vehicle braking performance. The operator can control the engine brake for different operating conditions.

Optional Equipment

Optional cold climate features available are an oil pan heater and a coolant heater. Both heaters use an electric element to warm engine fluids in cold weather.

The oil pan heater warms engine oil to ensure optimum oil flow to engine components.

The coolant heater warms the engine coolant surrounding the cylinders. Warmed engine coolant increases fuel economy and aids start-up in cold weather.

Chassis Mounted Equipment

- The chassis mounted fuel filter/water separator removes a majority of the water and foreign particles that may enter the fuel system from the supply tank(s). This filter works with the engine mounted fuel module to eliminate foreign matter and moisture from the fuel before entering the fuel injection system.
- The Low Temperature Radiator (LTR) regulates the temperature of the LPCAC and the low temperature stage of the EGR cooler. The LTR is mounted in front of the radiator cooling package, and requires connections to the engine cooling system.
- The HPCAC lowers the temperature of the after the air is compressed by the turbochargers and has no connections to the engine cooling system. The HPCAC is an air-to-air cooler. The HPCAC is mounted in front of the radiator cooling package.
- The Diesel Oxidation Catalyst (DOC) oxidizes hydrocarbons and carbon monoxide, provides heat for exhaust system warm-up, aids in temperature management for the Diesel Particulate Filter (DPF), and oxidizes NO into NO₂ for passive DPF regeneration. The DOC is monitored by the ECM using one Diesel Oxidation Catalyst Inlet Temperature (DOCIT) sensor positioned at the DOC inlet, and one Diesel Oxidation Catalyst Outlet Temperature (DOCOT) sensor positioned at the DOC outlet.
- The DPF temporarily stores carbon-based particulates, oxidizes stored particulates, stores non-combustible ash, and provides required exhaust back pressure for proper engine performance. The DPF is monitored by the ECM using one Diesel Particulate Filter Outlet Temperature (DPFOT) sensor located at the outlet of the DPF, and one Diesel Particulate Filter Differential Pressure (DPFDP) sensor located on or near the DPF.

Engine Component Locations

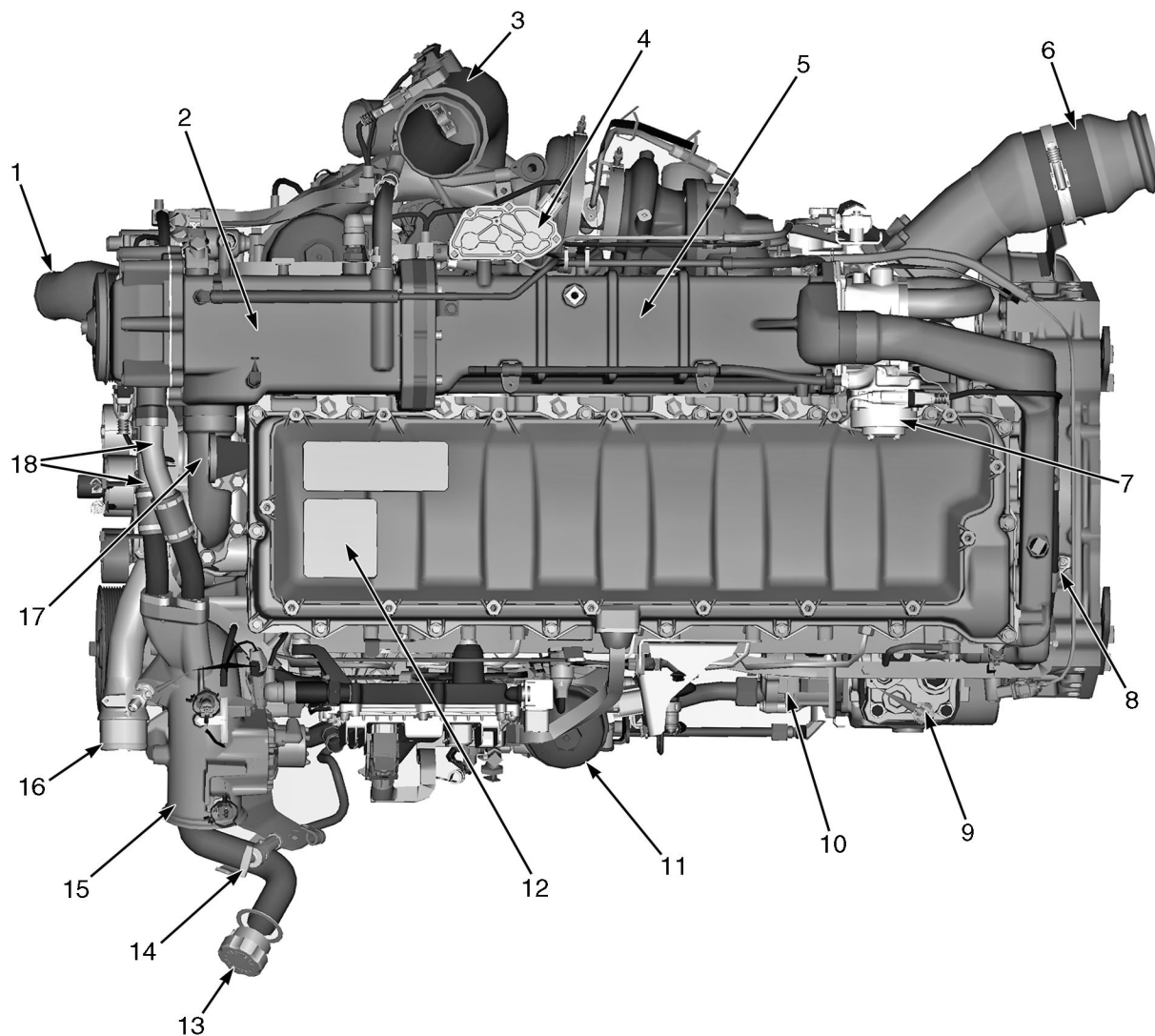

V00095

Figure 3 Component location – top view

- | | | |
|---|---|--------------------------------------|
| 1. Engine coolant inlet | 6. Pre-DOC assembly (PDOC) | 13. Engine oil fill |
| 2. Exhaust Gas Recirculation (EGR) cooler (low temperature stage) | 7. EGR Valve (EGRV) | 14. Engine oil level gauge |
| 3. Air intake duct | 8. Crankshaft Position (CKP) Sensor | 15. Intake throttle duct assy |
| 4. Air Control Valve (ACV) assembly | 9. Air compressor | 16. Engine coolant outlet |
| 5. EGR cooler (high temperature stage) | 10. Power steering pump | 17. EGR cooler outlet pipe (coolant) |
| | 11. Engine mounted secondary fuel filter access | 18. EGR cooler outlet tubes (gases) |
| | 12. Emission label (location) | |

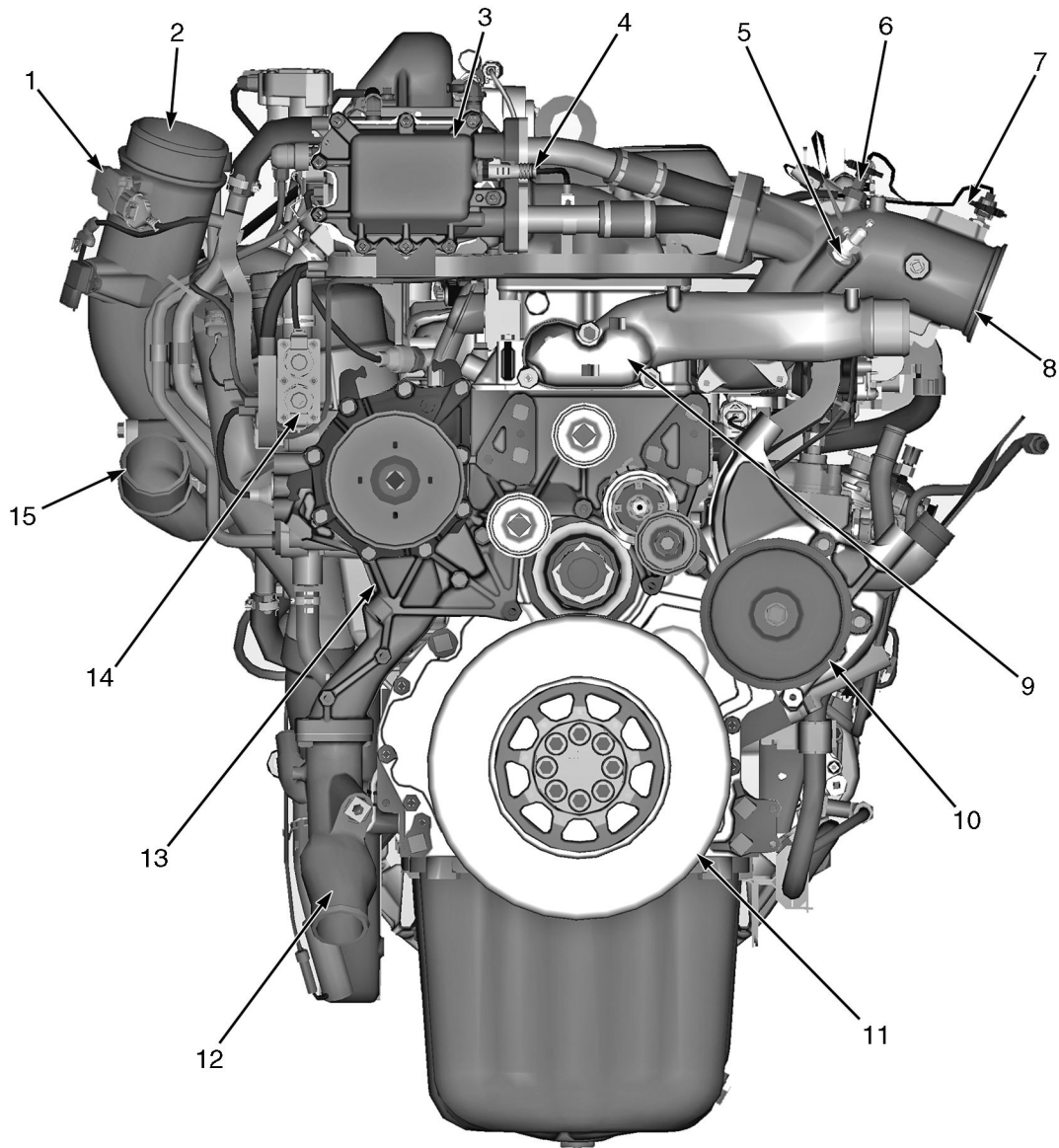

V00096

Figure 4 Component location – front view

- | | | |
|--|--|---------------------------------------|
| 1. Mass Air Flow (MAF) sensor | 6. Intake Manifold Pressure (IMP) sensor | 11. Vibration damper |
| 2. Air inlet duct | 7. Charge Air Cooler Outlet Temperature (CACOT) sensor | 12. Water engine inlet |
| 3. EGR cooler | 8. Intake throttle duct assy | 13. Water distribution housing. |
| 4. EGR Temperature (EGRT) sensor | 9. Thermostat housing | 14. Coolant Control Valve (CCV) |
| 5. Inlet Air Heater Fuel Igniter (IAHFI) | 10. HP pump pulley | 15. HP turbocharger compressor outlet |

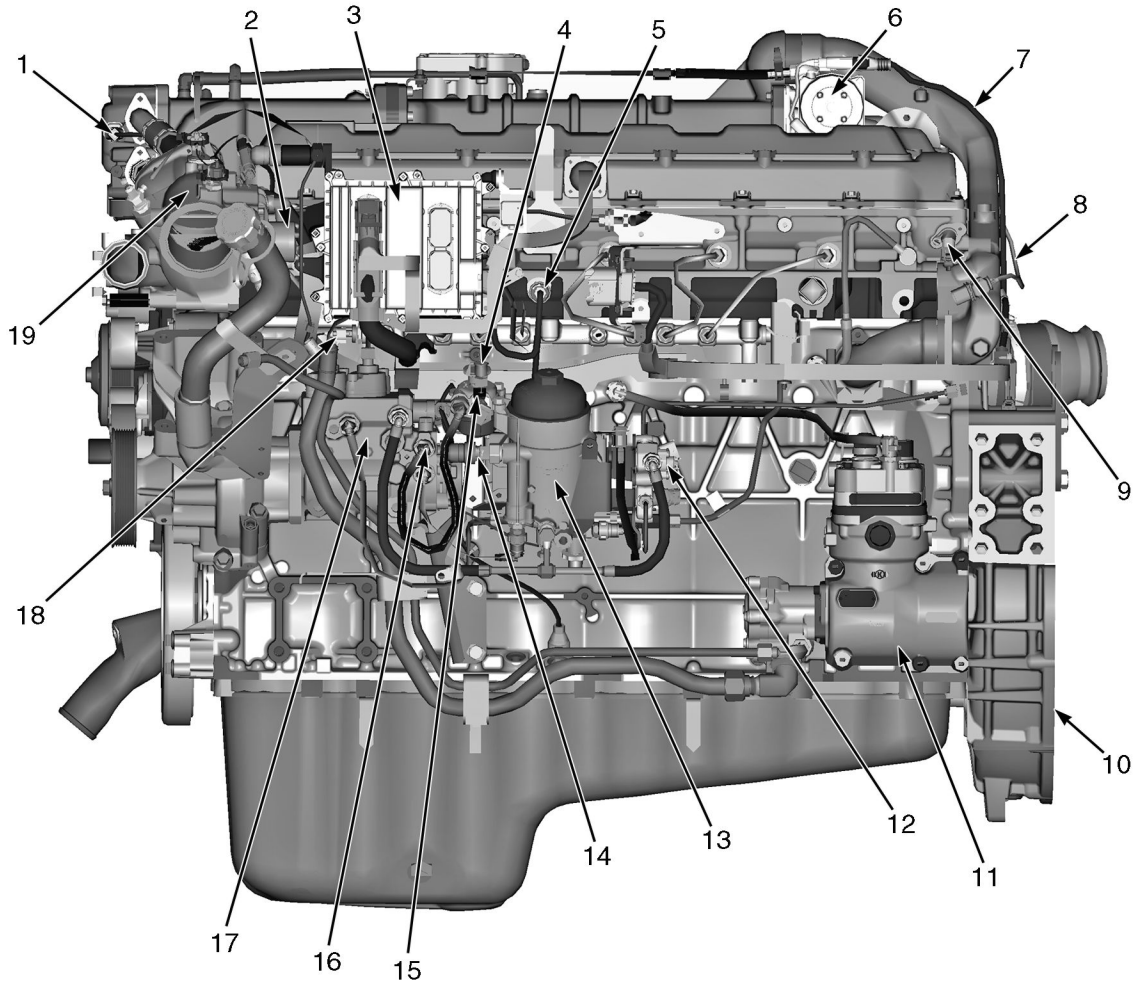

V00097

Figure 5 Component location – left view

- | | | |
|--|---|---|
| 1. EGRT sensor | 7. EGR cooler coolant manifold | 14. Fuel Delivery Pressure (EDP) sensor |
| 2. Engine Throttle Valve (ETV) | 8. Oxygen Sensor harness | 15. Fuel primer pump assembly |
| 3. ECM | 9. Camshaft Position (CMP) sensor | 16. LP fuel pump |
| 4. Low Pressure (LP) fuel pressure test port | 10. Flywheel Housing | 17. HP fuel pump |
| 5. Intake Manifold Temperature (IMT) | 11. Air Compressor | 18. Fuel Rail Pressure (FRP) sensor |
| 6. EGRV | 12. DSI unit | 19. Intake throttle duct assembly |
| | 13. Engine mounted secondary fuel filter access | |

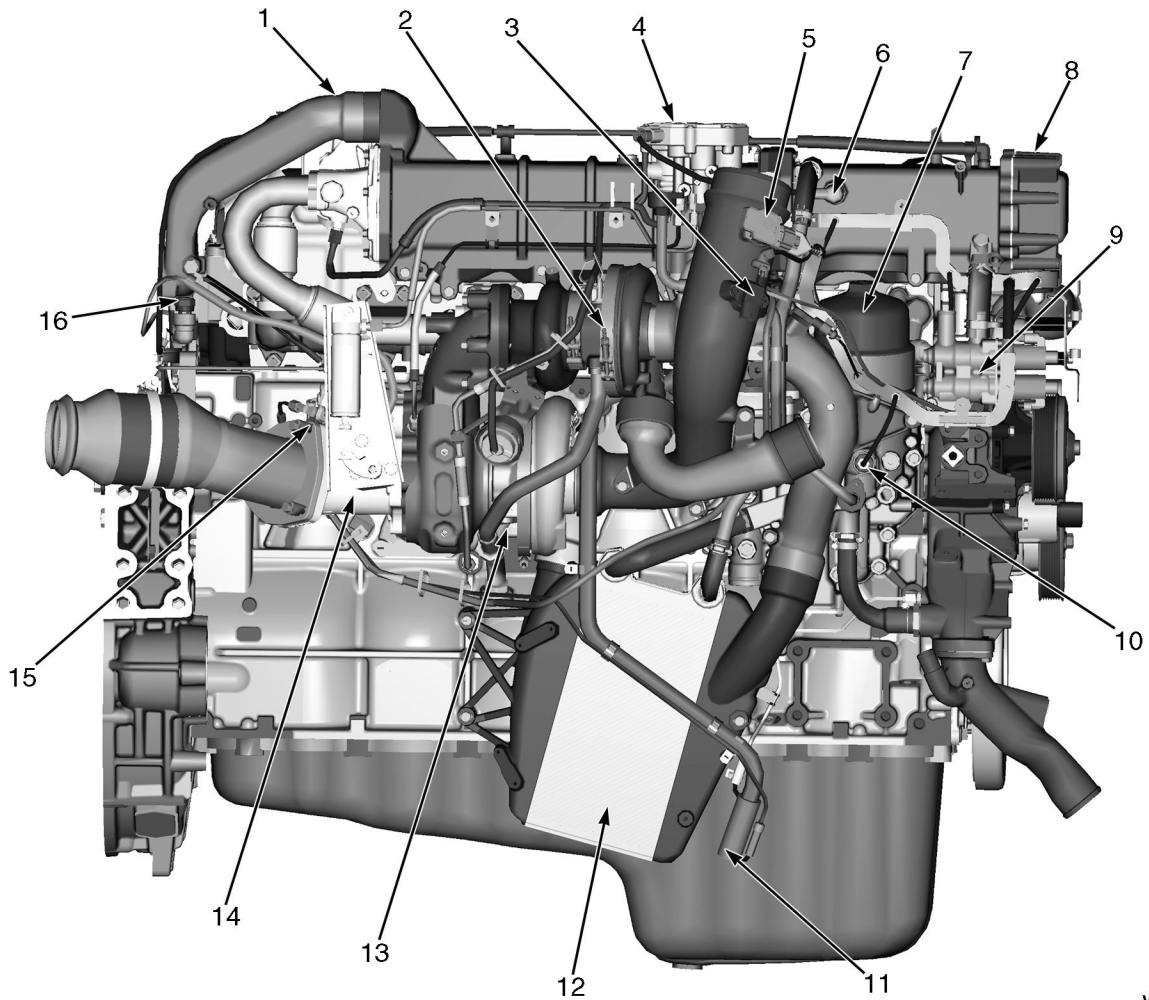

V00098

Figure 6 Component location – right view

- | | | |
|--|--|--|
| 1. EGR cooler coolant manifold | 7. Oil filter cap | 13. LP Turbocharger |
| 2. HP turbocharger | 8. EGR Cooler | 14. Engine Back Pressure Valve (EBPV) |
| 3. Humidity Sensor (HS) / Inlet Air Temperature (IAT) sensor | 9. CCV | 15. Hydrocarbon Injector (HCI) assembly |
| 4. Air Control Valve (ACV) assembly | 10. Engine Oil Pressure (EOP) sensor | 16. Engine Coolant Temperature 1 (ECT1) sensor |
| 5. MAF sensor (if equipped) | 11. Crankcase Oil Separator (CCOS) | |
| 6. Engine Coolant Temperature 2 (ECT2) | 12. Low-Pressure Charge Air Cooler (LPCAC) | |

Air Management System

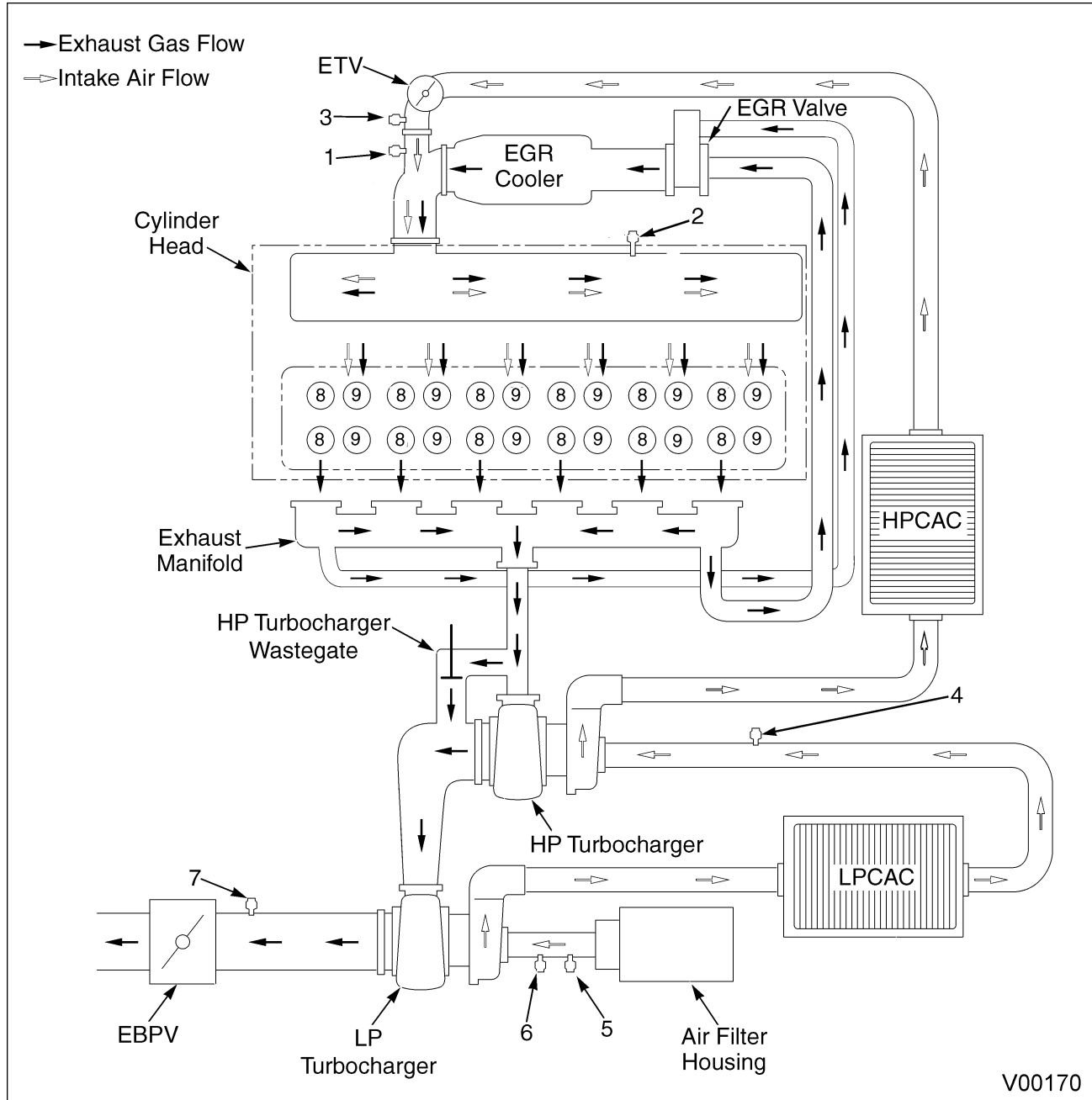

V00170

Figure 7 Air Management System

- | | | |
|---|--|------------------------|
| 1. EGRT sensor | 4. LP Boost/LP Temperature sensor | 7. Oxygen Sensor (O2S) |
| 2. IMP sensor | 5. MAF sensor (if equipped) | 8. Exhaust Valve |
| 3. Charge Air Cooler Outlet Temperature (CACOT) | 6. Humidity Sensor (HS) / Inlet Air Temperature (IAT) sensor | 9. Intake Valve |

Airflow

Air flows through the air filter housing and enters the Low-pressure (LP) turbocharger. The LP turbocharger increases the pressure and temperature of the filtered intake air before it enters the LPCAC. Cooled and compressed air then flows from the LPCAC into the HP turbocharger (compressor inlet). Hot and highly compressed air flows from the HP turbocharger (compressor outlet) into the HPCAC where it is cooled, and into the intake throttle duct, and continues through the Engine Throttle Valve (ETV). The HP and LP turbochargers increase pressures up to 345 kPa (50 psi).

If the EGRV is open, exhaust gases pass through the EGR cooler and into the intake throttle duct where it is mixed with filtered air. This mixture flows into the intake manifold, and then the cylinder head. The intake manifold is an integral part of the cylinder head casting.

During cold weather, the inlet air heater assist system rapidly activates the heater element, vaporizing and igniting small quantities of fuel into the air inlet duct.

After combustion, exhaust gases exit through the cylinder head exhaust valves and ports. The exhaust gas is forced through the exhaust manifold where, depending on EGRV position, it is split between the EGR system and the exit path through the HP turbocharger, LP turbocharger, and EBPV.

The EBPV is operated by a pneumatic actuator. When the ACV is applied, the EBPV restricts flow and increases exhaust back pressure. Operation of the EBPV is controlled by the ECM using the ACV and the Turbocharger 1 Turbine Outlet Pressure (TC1TOP) sensor. When the EBPV is opened, exhaust back pressure is released.

Exhaust gases exiting the engine systems flow through the EBPV, then through the vehicle Aftertreatment (AFT) system, and out the exhaust tail pipe.

**CLICK HERE TO
Download**

Thank you very much!

Have questions.

Please write to me.

admin@manualtrucks.com